



RAM™-DPJ WHISPAIR™ High-Pressure Blowers

Howden



Design and Construction Features

- Single stage operation to 30 psig
- No valves, vanes or teflon rings to wear
- Alloy steel timing gears
- Cylindrical roller bearings
- Piston ring air seals
- Lip-type oil seals, (optional mechanical seal)
- Splash oil lubrication
- Horizontal & vertical configurations available

RAM™ stands for Reliability, Availability and Maintainability. Today, more than ever, Roots is committed to supplying our customers with reliable products manufactured with state-of-the-art CNC machine tools. Production and inventory are being scheduled and controlled to ensure these units will be available when you need them. Design improvements such as repositionable rugged steel mounting feet and die-cast aluminum drive end covers and gear covers help to reduce installation costs and make normal maintenance easier.

Basic dry vacuum pump description

The ROOTS™ RAM™-DPJ WHISPAIR™ rotary blower has an exclusive discharge jet plenum design which allows cool, pressurized system air to flow into the cylinder. This unique design permits operation at high pressure levels with a single stage unit.

The RAM high pressure blower is designed for continuous operation at discharge pressures up to 30 psig. It has no valves, vanes or Teflon rings.

The basic model is designed using integral-shaft ductile iron impellers with an involute profile. The casing and headplates are grey iron, while the drive and cover and gear cover are die cast aluminum. Carburized and ground alloy steel spur timing gears are taper mounted on the shafts, secured with a locknut. Cylindrical roller bearing are splash lubricated at both the gear end and drive end.

Piston rings reduce air leakage through the headplate bores and lip-type oil seals prevent lubricants from entering the air chamber. Mechanical seals are available upon request.

Warranty period

Twelve (12) months from date of original unit start-up or 18 months from date of original shipment, whichever occurs first.

Operating principle

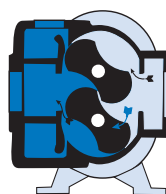

Position 1

Incoming air is trapped between the impellers. Simultaneously, pressurized air is being discharged.

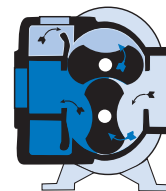

Position 2

As the upper impeller passes the jet plenum, cooled, pressurized air flows into the space between the impeller and cylinder. This cools the trapped air, helps control thermal growth and allows higher discharge pressures.

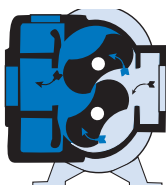

Position 3

The trapped air is then moved into the discharge flange (left). Backflow is reduced, resulting in lower operating noise level and reduced shock loading on the impellers.

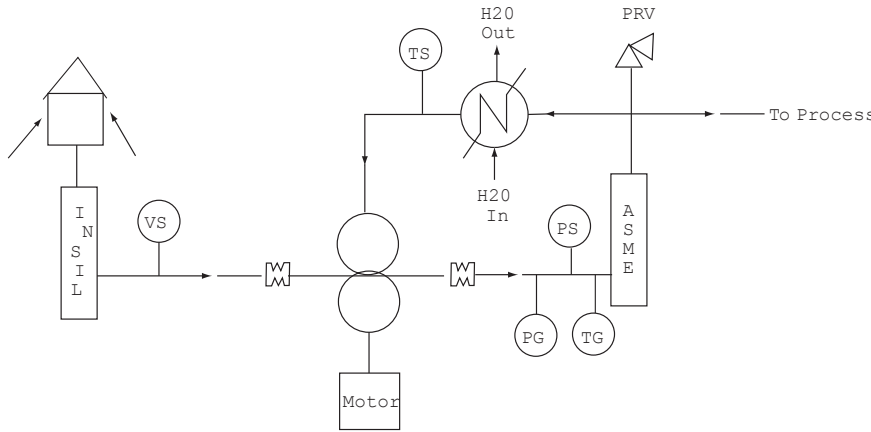

For further information contact

Howden Roots
 900 W. Mount St.
 Connersville
 Indiana
 USA
 47331
 Tel: +1 765 827 9200
 Web: www.howden.com

Vertical configuration

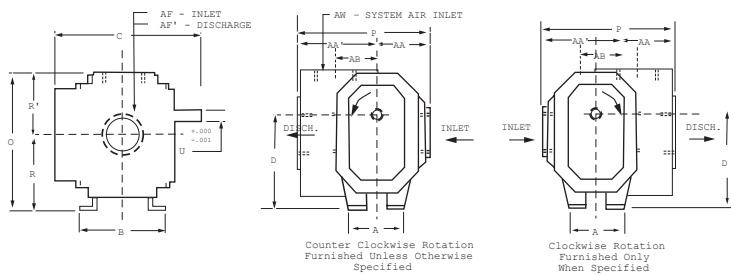

Horizontal configuration

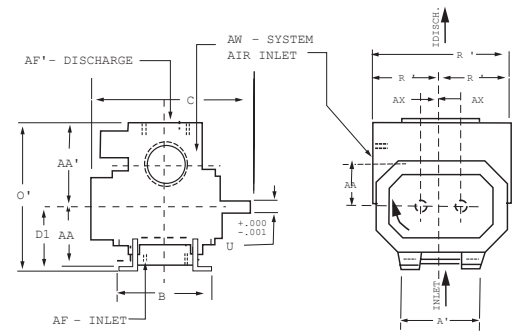

Dimensional table

Frame Size	A	A'	B	C	Drive Shaft Location		O	O'	P	P'	R	U	Keyway	AA	AA'	AB	AF	AF'	AW	AX	WGT.
					D	D'															
406 DPJ	8.00	11	10.75	20.5	11.25	7.5	16.38	18	17.75	14.75	9	1.5	.375 x .188	7.25	15.25	10.5	4 NPT	5 NPT	4 NPT	2.25	365

Notes: 1. All dimensions are in inches. 2. Weights are in pounds, and are approximate.

Performance table

Frame Size	Speed RPM	15 PSI		20 PSI		25 PSI		30 PSI	
		CFM	BHP	CFM	BHP	CFM	BHP	CFM	BHP
406 DPJ	4000	518	47	494	62	474	76	455	91
	3070	362	35	339	46	319	57	300	69
	2320	237	26	214	35	193	43	175	51
	1750	142	19	119	26	98	32	80	39

Notes:
 Ratings based on inlet air at standard pressure of 14.7 psia, standard temperature of 68°F, and specific gravity of 1.0